

Universal DMX Relay *User's Guide*

Specifications:

Voltage: 120vac 60Hz (230vac 50Hz available)

Power Input: 40mA plus load

Power Cord: 6 ft. 15amp with NEMA type 5-15P plug

Power Out: Input line voltage switched to NEMA type 5-15R receptacle, maximum 15A inductive or non-inductive load

Terminal Block: (6 position)

- low voltage 3A relay contact 1a
- low voltage 3A relay contact 1b
- +10vdc regulated 30mA
- +5vdc regulated 250mA
- ground
- 4.7k ohm pull up/down resistor

Enclosure: 5.5"(L) x 4.6"(W) x 2.3"(H) durable black CRS

Weight: 2 lb.

DMX Address Setting:

Set the DMX address that the Universal DMX relay will respond to. Refer to the following table for correct dip switch settings.

DMX Address	Universal DMX Relay Dip Switch								
	1	2	3	4	5	6	7	8	9
001	-	-	-	-	-	-	-	-	-
002	ON	-	-	-	-	-	-	-	-
003	-	ON	-	-	-	-	-	-	-
004	ON	ON	-	-	-	-	-	-	-
005	-	-	ON	-	-	-	-	-	-
006	ON	-	ON	-	-	-	-	-	-
007	-	ON	ON	-	-	-	-	-	-
008	ON	ON	ON	-	-	-	-	-	-
009	-	-	-	ON	-	-	-	-	-
010	ON	-	-	ON	-	-	-	-	-
011	-	ON	-	ON	-	-	-	-	-
012	ON	ON	-	ON	-	-	-	-	-
“ “	“	“	“	“	“	“	“	“	“
256	ON	ON	ON	ON	ON	ON	ON	ON	-
“ “	“	“	“	“	“	“	“	“	“
512	ON	ON	ON	ON	ON	ON	ON	ON	ON
Weighted Value	1	2	4	8	16	32	64	128	256

DMX address = Add the weighted value of all the dip switches that are turned ON + 1

MLSC Inc (Meteor Light and Sound Co.)

Mailing address: P.O. BOX 578; Shipping: 8000 Madison Pike, Madison, AL 35758

Phone: (256) 461-8000 Sales: (256) 772-9626 Fax: (256) 461-7708

sales@meteor-usa.com

www.meteor-usa.com

www.meteor-global.com

Switching Line Voltage Loads:

The Universal DMX Relay's input line voltage is switched to a standard NEMA type 5-15R receptacle. Up to a 15A inductive or non-inductive load is permitted. The relay will close energizing the load whenever the DMX level being decoded rises above 127. The relay will open de-energizing the load whenever the level falls below 128.

Switching Low Voltage Loads:

Low voltage loads are easily switched utilizing the secondary switch closures labeled 'relay 1a' and 'relay 1b' found on the 6 position terminal strip. Limit low voltage loads to a maximum of +-48V and 3 amps.

+5V / 10V Logic Level Switching:

The 6 position terminal strip allows for a variety of switching configurations. The following diagrams demonstrate possible solutions to common switching task:

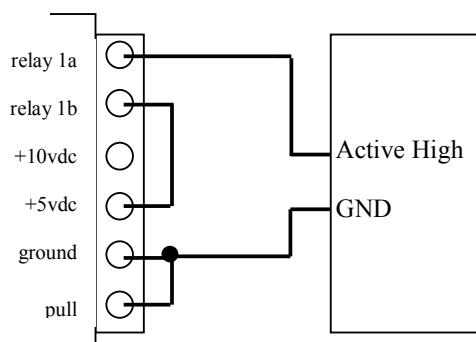

Positive 5V Logic

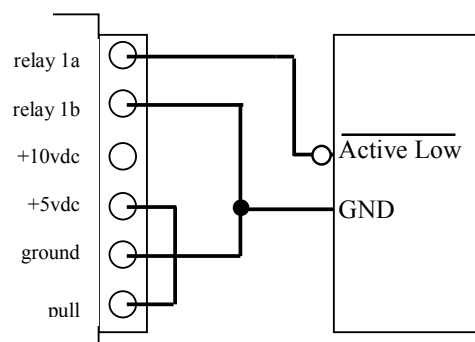

Negative 5V Logic

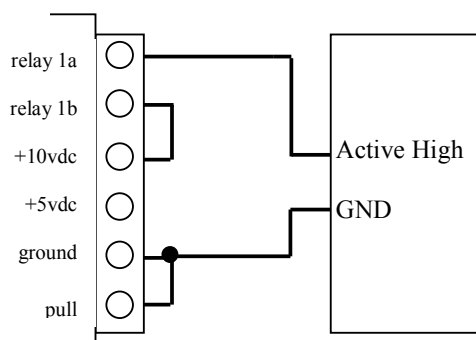

Positive 10V Logic

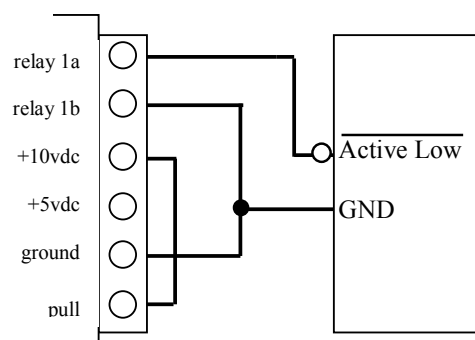

Negative 10V Logic

MLSC Inc (Meteor Light and Sound Co.)

Mailing address: P.O. BOX 578; Shipping: 8000 Madison Pike, Madison, AL 35758

Phone: (256) 461-8000 Sales: (256) 772-9626 Fax: (256) 461-7708

sales@meteor-usa.com

www.meteor-usa.com

www.meteor-global.com

DMX Line Monitor:

The Universal DMX Relay is equipped with a comprehensive DMX line monitor designed to help isolate common line problem.

ERROR CODES		POSSIBLE FAULT
DMX LED	RELAY LED	
Full On or Off	3 second flutter followed by 2 seconds Off	Disconnected or cut data cable, Control signal not present
Dim or Fluttering	3 second flutter followed by 2 seconds Off	Reversed data lines (pins 2 & 3 swapped), Invalid DMX512 control signal

LED Indicators:

Power - The red power indicator will illuminate whenever line voltage is applied. If the indicator fails to light you should check that the 15A fuse is not blown and that correct line voltage is being applied.

DMX - The green dmx indicator will flutter or light dimly when a valid DMX512 signal is present.

Relay - The yellow relay indicator will illuminate whenever the relay is active. Line voltage will be present at the output connector and the low voltage relay contact will be closed. The indicator will flutter for 3 seconds and turn Off for 2 seconds in the event of DMX line errors.

DMX Line Termination:

The Universal DMX Relay is equipped with a user selectable 120 ohm terminating resistor. To enable line termination set dip switch number 10 to the ON position. Line termination should only be activated when the Universal DMX Relay is the last unit in the chain of units.

MLSC Inc (Meteor Light and Sound Co.)

Mailing address: P.O. BOX 578; Shipping: 8000 Madison Pike, Madison, AL 35758

Phone: (256) 461-8000 Sales: (256) 772-9626 Fax: (256) 461-7708

sales@meteor-usa.com

www.meteor-usa.com

www.meteor-global.com